

MACHINE SKATES

Advanced high-strength steel skates with non floor damaging wheels

Load Capacity:
**25 tons each -or-
50 tons combined**



Model A25
Steerable Front

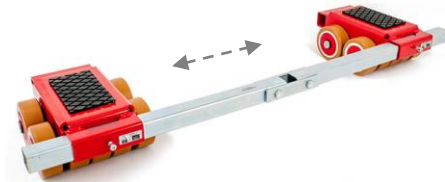

Model B25
Adjustable-Width Rear

Example of Load Distribution

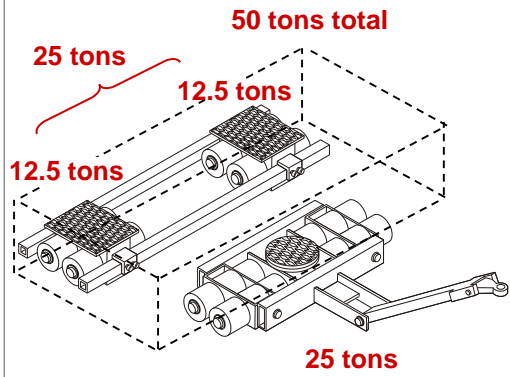

3-point skate systems do not slip during pulling & tugging actions

» Each Model Sold Separately
Mix & Match as Needed! «

Included	One steerable skate with non floor marking wheels and pulling handle.	One straight-line 2-part skate with non floor marking wheels and connecting bar.
Load Capacity Each	25 tons • 50,000 lbs	25 tons • 50,000 lbs
Load Capacity Combined A25 + B25	50 tons • 100,000 lbs	
Height (from floor to top of load pad)	7.1"	7.1"
Dimensions (Width x Length)	34.7" x 23.3" without handle	12.9" x 16.9" each skate part without bars
Load Wheel Dimensions (Ø x Width)	5.5" x 2.3"	5.5" x 2.3"
Supporting Surface (each with anti-slip load pad)	Ø 8.5"	4.7" x 8.6"
Length of Connecting Bar	n/a	60.7"
Pulling Handle length (with towing eye)	57"	n/a
Weight	282 lbs	190 lbs
Manufacturer • MPN	JUNG • JLB 25 G	JUNG • JFB 25 G

Free lifetime rigging & technical support hotline!

JUWathan+® Wheels



with Aluminum Core

Patented wheel material is baked in oven over long period for elasticity and extreme toughness!

Non floor damaging	For smooth and rough floors	Overcomes small obstacles easily by molding around them to keep rolling.	Low floor pressure	Shock absorbent	Superior performance and durability over traditional polyurethane, composite or steel wheels
Non floor marking	For floors with cracks and dirt	No stop, up & over action required like with other wheels.	Low break out & low rolling resistance	Reliable under toughest working conditions	
	For both inside and outside use		Low push-pull force and low manpower requirements		



MADE IN GERMANY
By JUNG



5 Year Manufacturer's Warranty
(damage due to overloading not covered)