

MACHINE SKATES

Advanced high-strength steel skates with non floor damaging wheels

Load Capacity:
130 tons each



Model B130
Adjustable-Width Rear

Example of Load Distribution

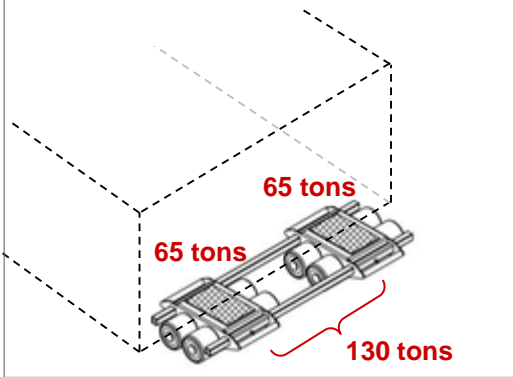

Skate with 3 axles for use on smooth level surfaces only

» Mix & Match as Needed with same or other JUNG skates of same height «

Included	One straight-line 2-part skate with non floor marking wheels and connecting bars.
Load Capacity Each	130 tons • 260,000 lbs
Height (from floor to top of load pad)	9.4"
Dimensions (Width x Length)	37.7" x 32.6" each skate part without bars
Load Wheel Dimensions (Ø x Width)	7.9" x 6.7"
Supporting Surface (each with anti-slip load pad)	17.3" x 11.8"
Length of Connecting Bar	118"
Weight	1797 lbs
Manufacturer • MPN	JUNG • JFB 120 H

Free lifetime rigging & technical support hotline!

**JUWathan+®
Wheels**

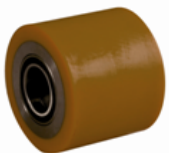

with Steel Core

Patented roller material is baked in oven over long period for elasticity and extreme toughness!

Non floor damaging	For smooth and rough floors	Overcomes small obstacles easily by molding around them to keep rolling.	Low floor pressure	Shock absorbent	Superior performance and durability over traditional polyurethane, composite or steel wheels
Non floor marking	For floors with cracks and dirt	No stop, up & over action required like with other wheels.	Low break out & low rolling resistance	Reliable under toughest working conditions	
	For both inside and outside use		Low push-pull force and low manpower requirements		



MADE IN GERMANY
By JUNG



5 Year Manufacturer's Warranty
(damage due to overloading not covered)