

## MACHINE SKATES

Advanced high-strength steel skates with non floor damaging wheels

Load Capacity:  
**15 tons each**



**Model B15**  
Adjustable-Width Rear

Example of Load Distribution

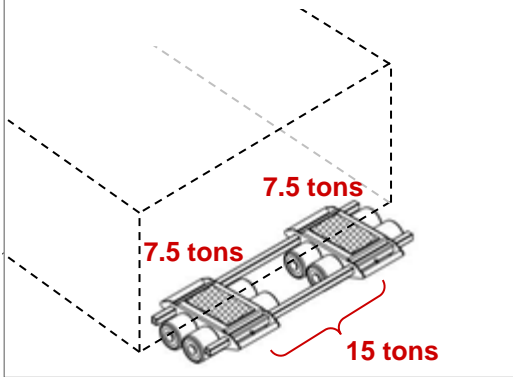

Skate with 3 axles for use on smooth level surfaces only

» Mix & Match as Needed with same or other JUNG skates of same height «

Included	One straight-line 2-part skate (not powered) and connecting bars.
Load Capacity Each	<b>15 tons • 30,000 lbs</b>
Height (from floor to top of load pad)	7.1"
Dimensions (Width x Length)	18.1" x 8.1" each skate part without bars
Load Wheel Dimensions (Ø x Width)	5.5" x 2.3"
Supporting Surface (each with anti-slip load pad)	8.6" x 4.7"
Length of Connecting Bar	60.6"
Weight	181 lbs
Manufacturer • MPN	JUNG • JFB 15 G

Free lifetime rigging & technical support hotline!

**JUWathan+®  
Wheels**



with Aluminum Core

**Patented roller material is baked in oven over long period for elasticity and extreme toughness!**

Non floor damaging	For smooth and rough floors	Overcomes small obstacles easily by molding around them to keep rolling.	Low floor pressure	Shock absorbent	<b>Superior performance and durability over traditional polyurethane, composite or steel wheels</b>
Non floor marking	For floors with cracks and dirt	No stop, up & over action required like with other wheels.	Low break out & low rolling resistance	Reliable under toughest working conditions	
	For both inside and outside use		Low push-pull force and low manpower requirements		



**MADE IN GERMANY**  
By JUNG



**5 Year Manufacturer's Warranty**  
(damage due to overloading not covered)