

Inclines

Machine Skates

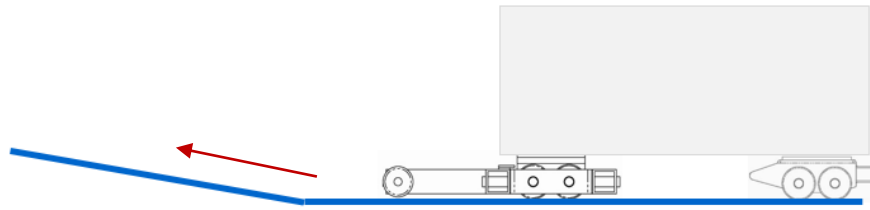

Made in Germany

© Toolwell, Inc. - all rights reserved -

Distributed by
Toolwell
North America

Movement over ramps can cause multiple problems. Safety considerations must be given to a multitude of factors.

Safety considerations

Illustration
1.1

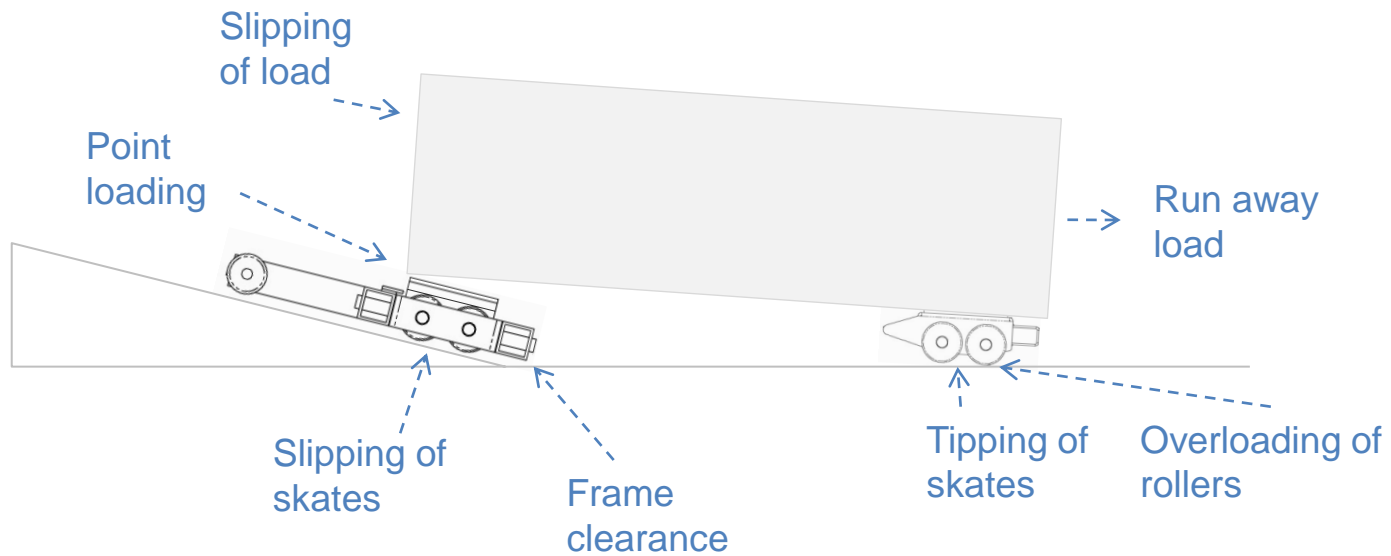

As the skates transition from a level plain and up a slope, the inclination angle of the payload gradually increases.

Slope angle and payload inclination angle

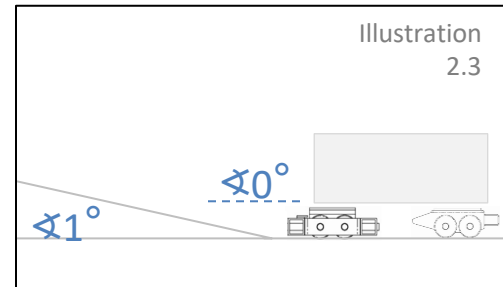
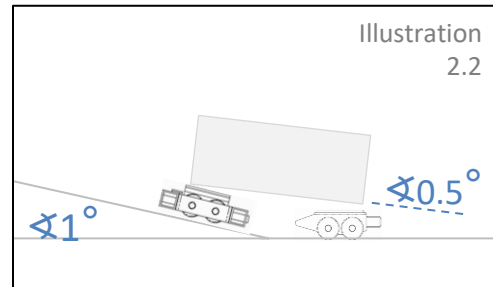
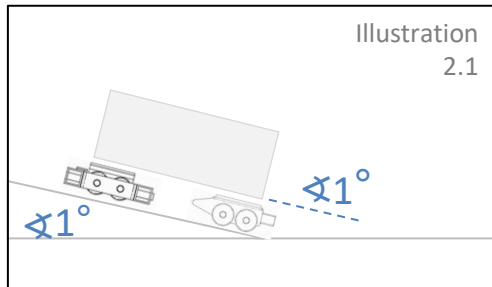

The inclination angle of the payload finally becomes greatest (equal the slope inclination) when front and rear dollies are on the slope.

Inclination angle of load = slope inclination

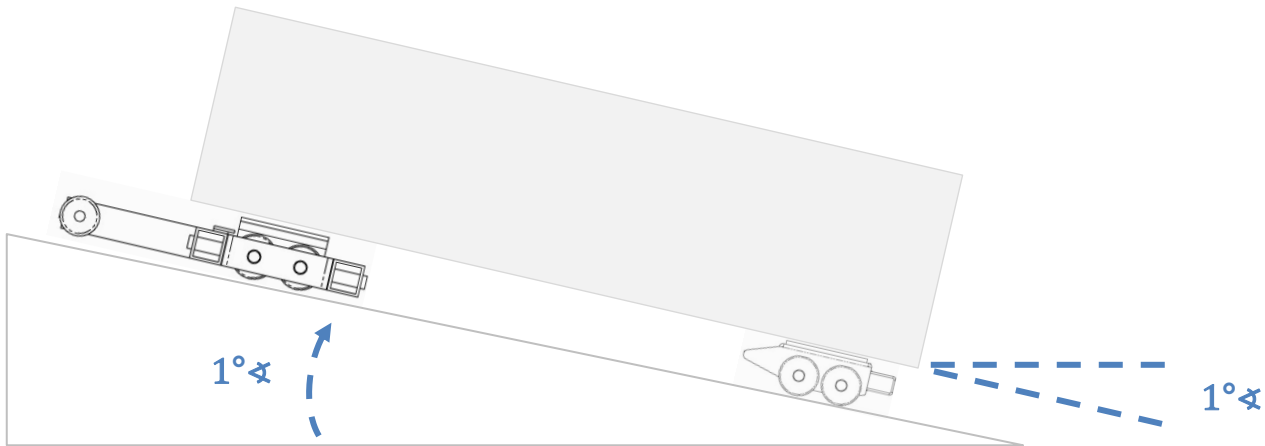

Illustration
3.1

The skates have such low rolling resistance that a load will run away even at the smallest declines.

Danger: Run away load on declines

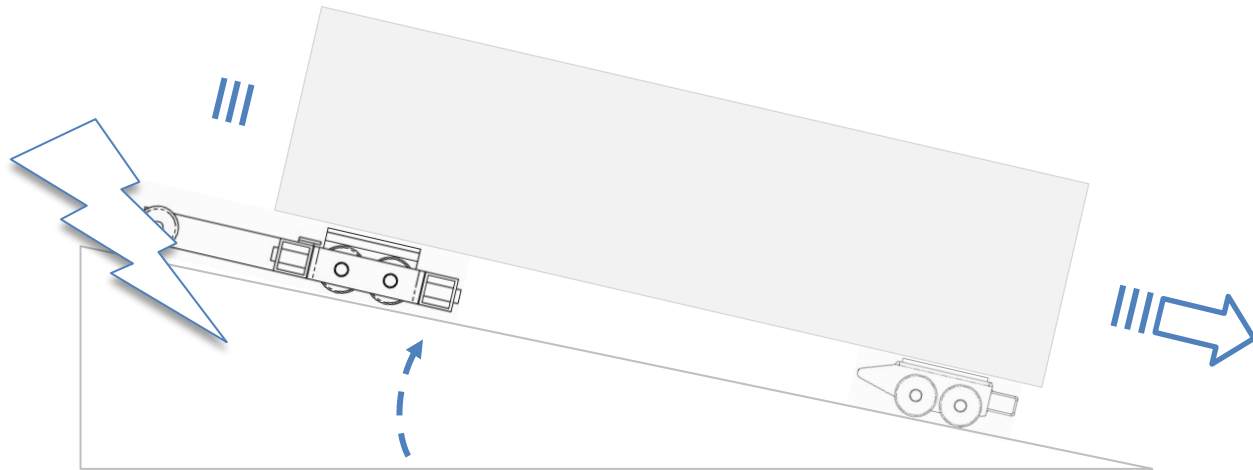

Illustration 4.1

The rubber load pad and the elastic roller material will compensate to some degree for the tilting of the load as well as tilting of the skates.

Compensation from elastic material

Illustration 5.1

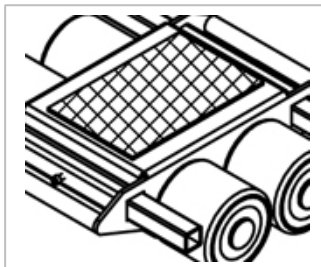
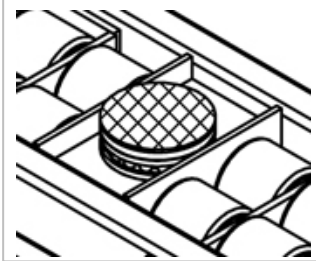
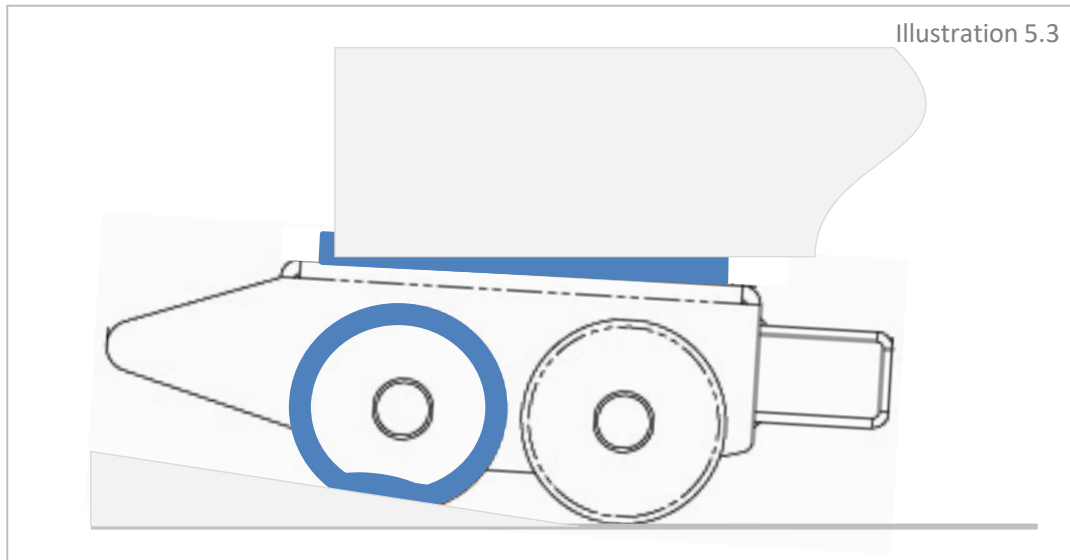

Illustration 5.2

Illustration 5.3



If the angle between the load and skate is too great, the contact area and the slip resistance (friction force) between the load pad and the load is dangerously reduced.

Reduced friction resulting in load slipping

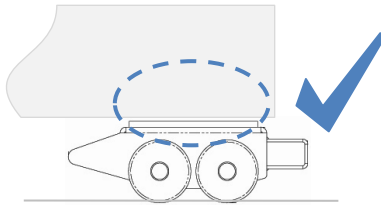

Illustration 6.1

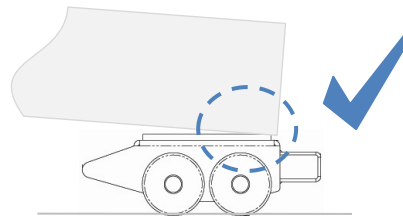

Illustration 6.2

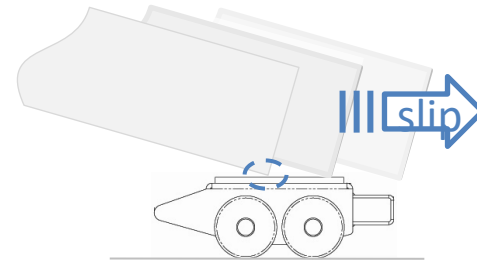

Illustration 6.3

If the angle between the load and skate is too great, the load weight is also no longer spread out across the skate but creates dangerous point loading.

Point loading

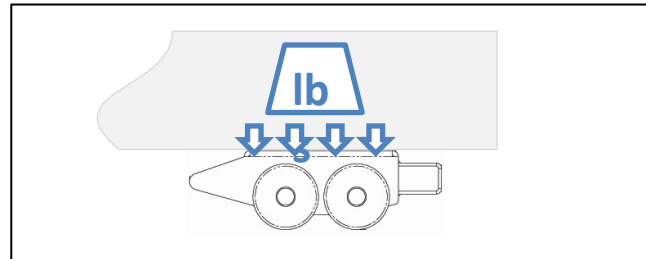

Illustration
7.1

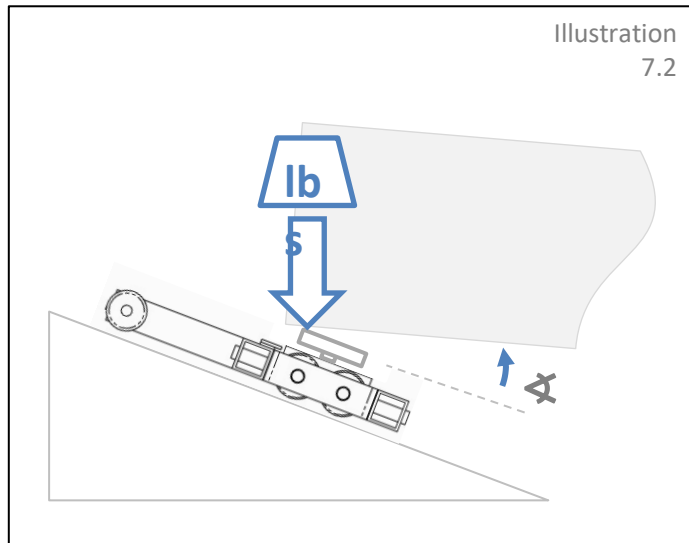

Illustration
7.2

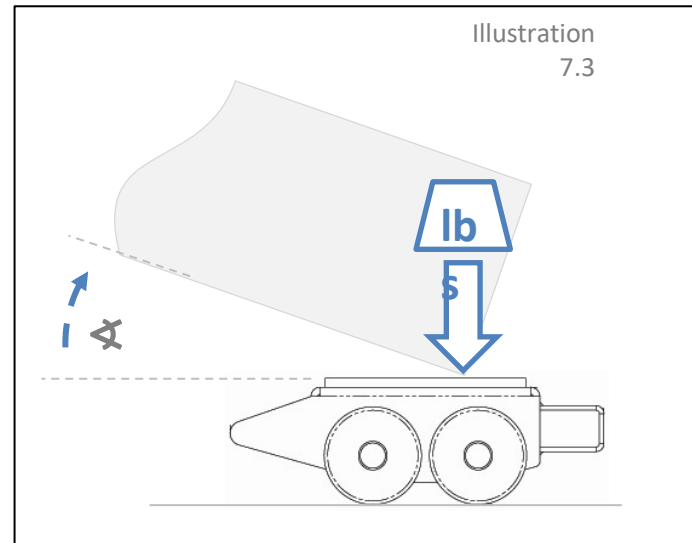
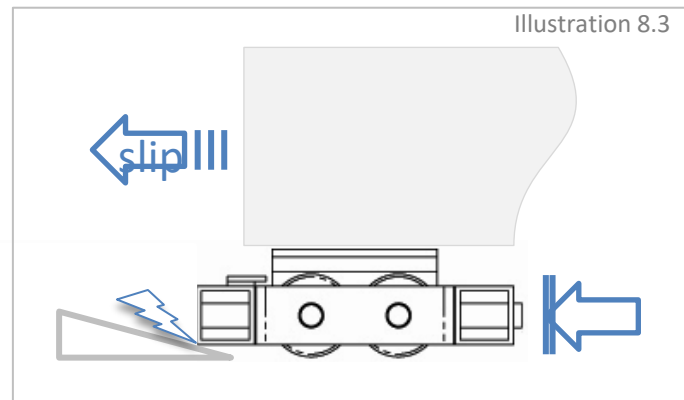
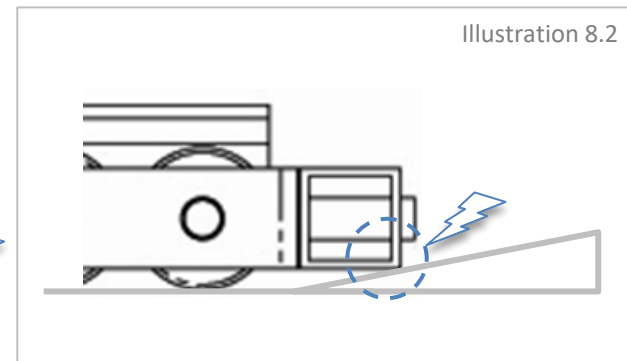
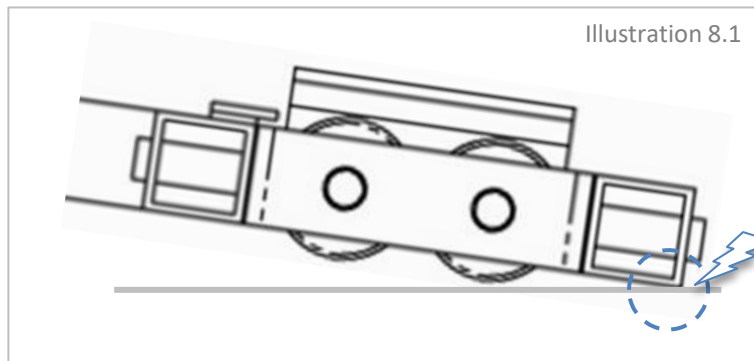

Illustration
7.3

On inclines as well as when the skates are tipped, the frame can hit the ground and stop the skate's movement. Any such caused abrupt stop can cause the load to slip.

Ground clearance with frame



If the skate leans with the load (load tilts loading platform), one axle is lifted of the ground and all the weight is concentrated on remaining axles.

Tipping of skates

Illustration 9.1

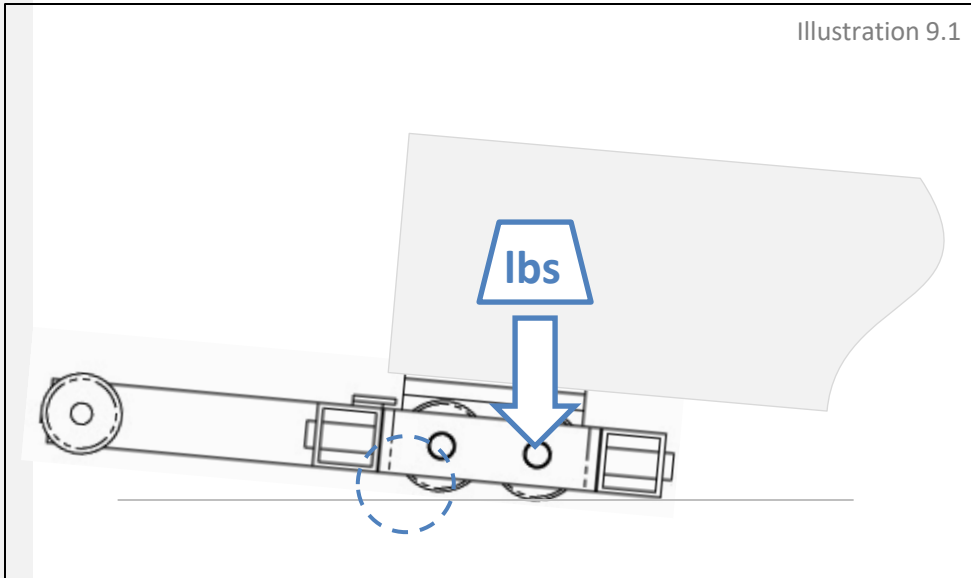
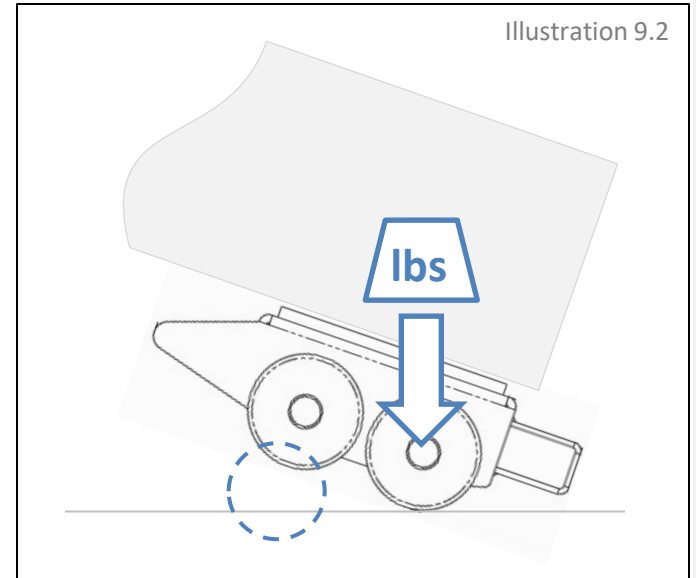

Illustration 9.2



In the event, that the load presses down on the edge of the loading platform (beyond the outer axle), the skate could slip out from under the load.

Slipping of skate

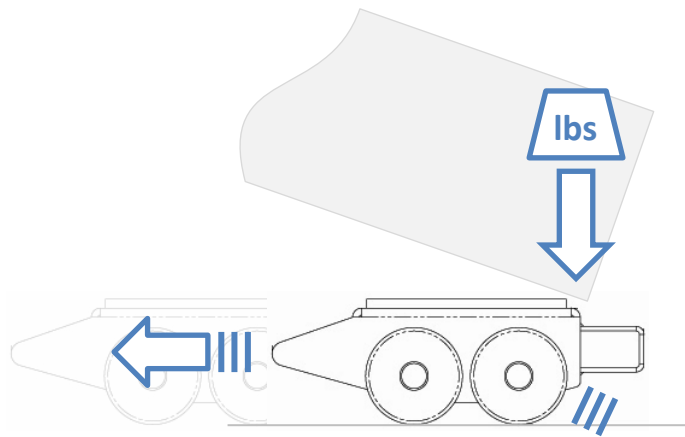

Illustration 10.1

It is consequently recommended to use the skates on flat surfaces only. Using the skates on inclines is dangerous.

Recommended use

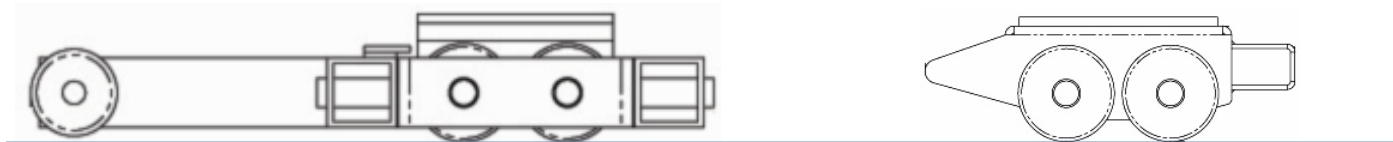

Illustration 11.1



Made in Germany

Toolwell

Distributed by

**Toolwell
North America**

© Toolwell, Inc. - all rights reserved

-